

REVISIONS			
REV	DESCRIPTION	DATE	APPROVED
NEW	DCN#: 0949		

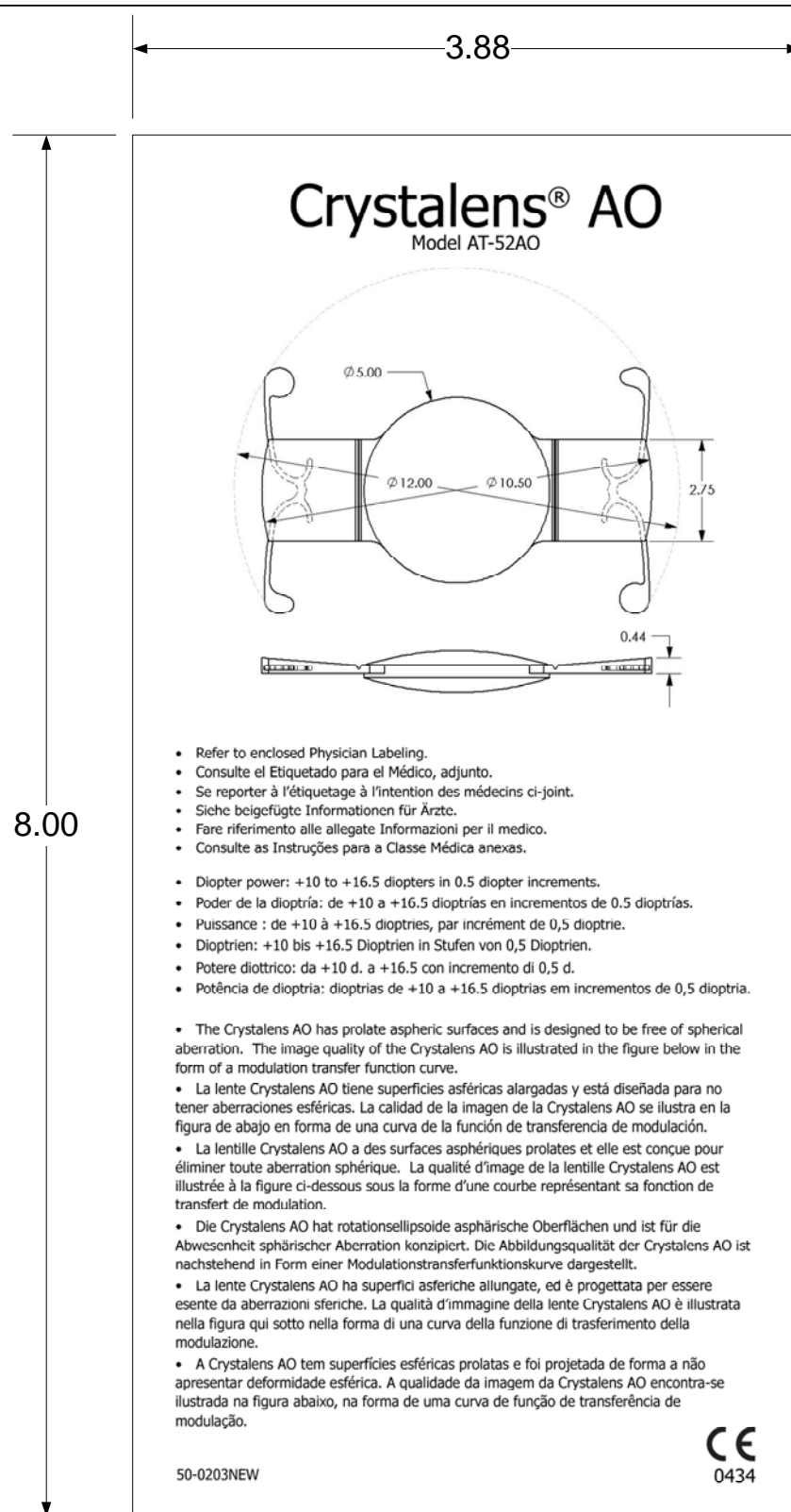

(FRONT)

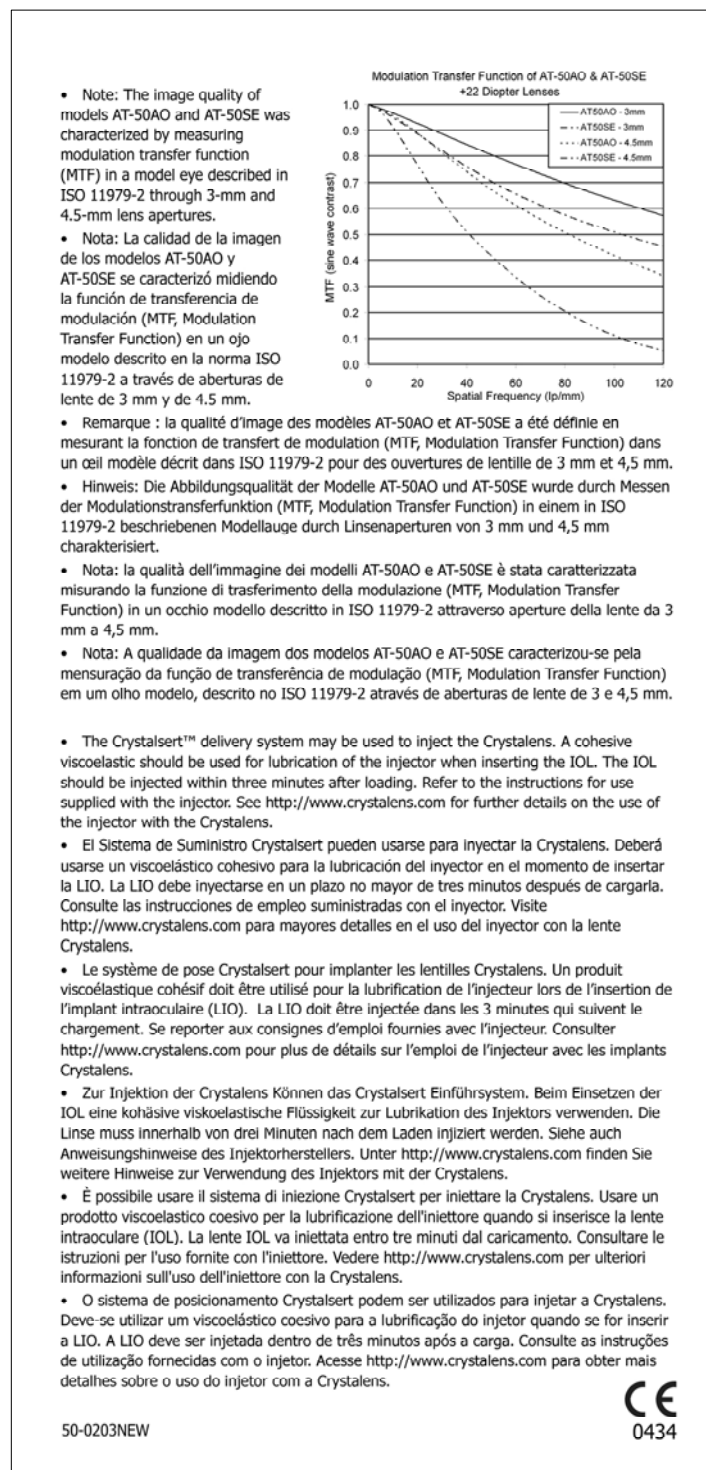

(BACK)

- INSPECT COLOR & CONTENT PER APPROVED MASTER.
  - PRINT IN BLACK INK.
  - STOCK: 95# GLOSS COVER.
- NOTES: UNLESS OTHERWISE SPECIFIED

THIS DOCUMENT IS ISSUED IN STRICT CONFIDENCE AND SHALL NOT BE REPRODUCED, COPIED OR USED AS THE BASIS FOR MANUFACTURE OR SALE OF ANY ITEM OTHER THAN THAT FOR WHICH IT WAS PROVIDED WITHOUT WRITTEN PERMISSION OF BAUSCH & LOMB.		NAME	DATE	30 ENTERPRISE SUITE 450 ALISO VIEJO, CA 92656	
DRAWN	JIR	09/01/09	Bausch & Lomb		
ENG			TITLE		
DO NOT SCALE DRAWING			OPER	DFU ADDENDUM, AT52AO	
UNLESS OTHERWISE SPECIFIED DIMENSIONS ARE IN INCHES TOLERANCES: ANGULAR: +/- 1 DEG X.XX +/- 0.03 X.XXX +/- 0.005			REG/QA	P/N	
				50-0203	
FILENAME			50-0203NEW.VSD	SIZE	DWG. NO.
Page 1 of 1			B	50-0203	
				REV	NEW